

MACHINES A SOUDER

WELDING MACHINES - SCHWEISSMASCHINEN
MAQUINA PARA SOLDAR - MACCHINE PER SALDARE

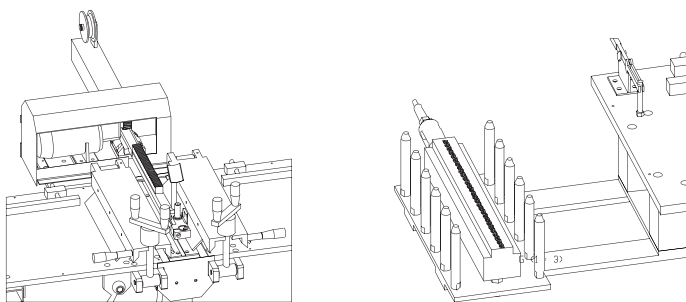

OPTIMIG 330 : VERSION 14

CODE

MACH330V14

- Avance automatique - Revenu par rampe à gaz
- Automatic torch feeding - gaz reheating
- Automatischer Vorschub - Gasrampen-Nachglühen
- Avance automático - revenido con rampa a gas
- Avanzamento automatico - ritorno con rampa di gas

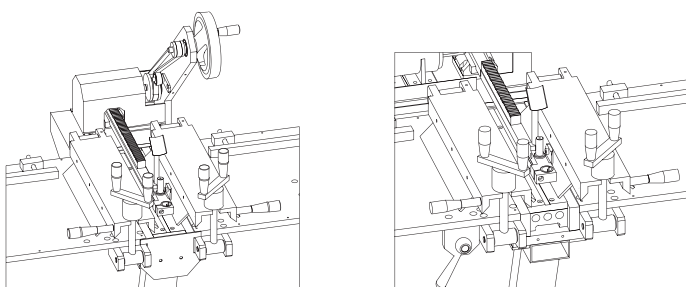

OPTIMIG 330 : VERSION 23

CODE

MACH330V23

- Avance manuelle - Revenu électrique
- Manual torch feeding - electric reheating
- Manueller Vorschub - elektrisches Nachglühen
- Avance manual - revenido eléctrico
- Avanzamento manuale - ritorno elettrico

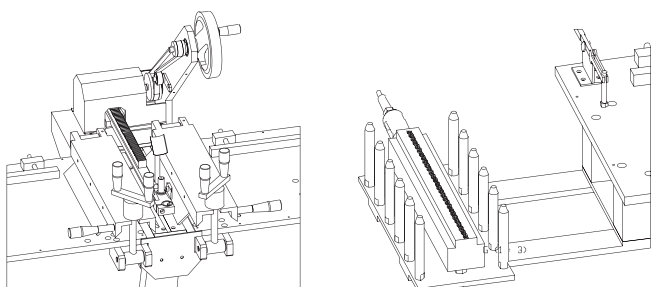

OPTIMIG 330 : VERSION 24

CODE

MACH330V24

- Avance manuelle - Revenu rampe à gaz
- Manual torch feeding - gaz reheating
- Manueller Vorschub - Gasrampen-Nachglühen
- Avance manual - revenido con rampa a gas
- Avanzamento manuale - ritorno con rampe di gas

OPTIMIG 420 : VERSION DE BASE

CODE

MACH420

OPTIONS POUR OPTIMIG 330

OPTIMIG 330 Options - OPTIMIG 330 Optionen - Opciones para OPTIMIG 330 - Opzioni OPTIMIG 330



- Cisaille incorporée
- Incorporated shear
- Integrierte Schere
- Cizalla incorporada
- Cesioia incorporata

CODE

MACH330OPT5



- Table de finition escamotable

- Folding weld finishing table
- Abklappbarer Tisch für Endbearbeitung
- Mesa de acabado escamotable
- Tavola di finitura

CODE

MACH330OPT6



- Voltage à préciser à la commande
- Voltage to be specified on order
- Volte bei Bestellung genau angeben
- Voltaje a precisar al pedido
- Voltaggio all'ordine da specificare